

AIR WALL

The AIR WALL is an extensible fixed support in matte black steel.

This LCD monitor fixation system adopts a sober and pure design, making the most of the content displayed. Its back cover and horizontal mats hide all cables in a minimal space. The customizable backlight cover will also enhance the interior of your agency.

Its design make it fit all spaces from 1.89m to 2.6m between two walls.

Compatible with 49", 55" and 75" screens in landscape format only, the support requires a minimum distance of 10cm between the screen and the window.

AVANTAGES



Black
Color



Designed and manufactured
In France



Quick and easy
Installation



Light and thin
Structure

DIMENSIONS (mm)

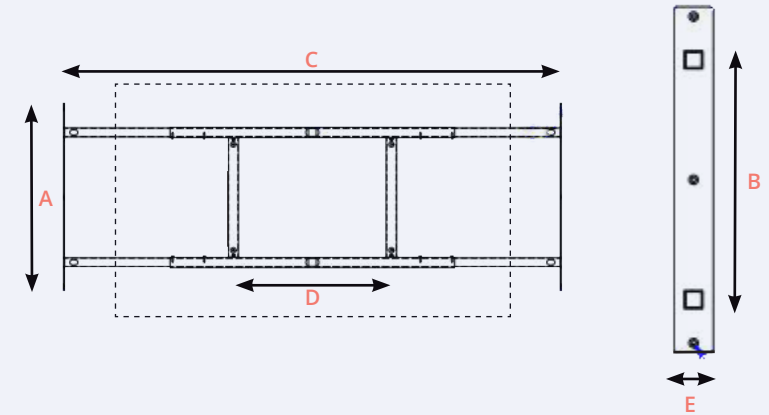

A	B	C	D	E
709	480	Min : 1892 Max : 2662	600	80



75" screen position

50 Route de la Reine
92 100 Boulogne-Billancourt
FRANCE - +33 (0)1 49 21 00 61
contact@vitrinemedias.com
www.vitrinemedias.com



