

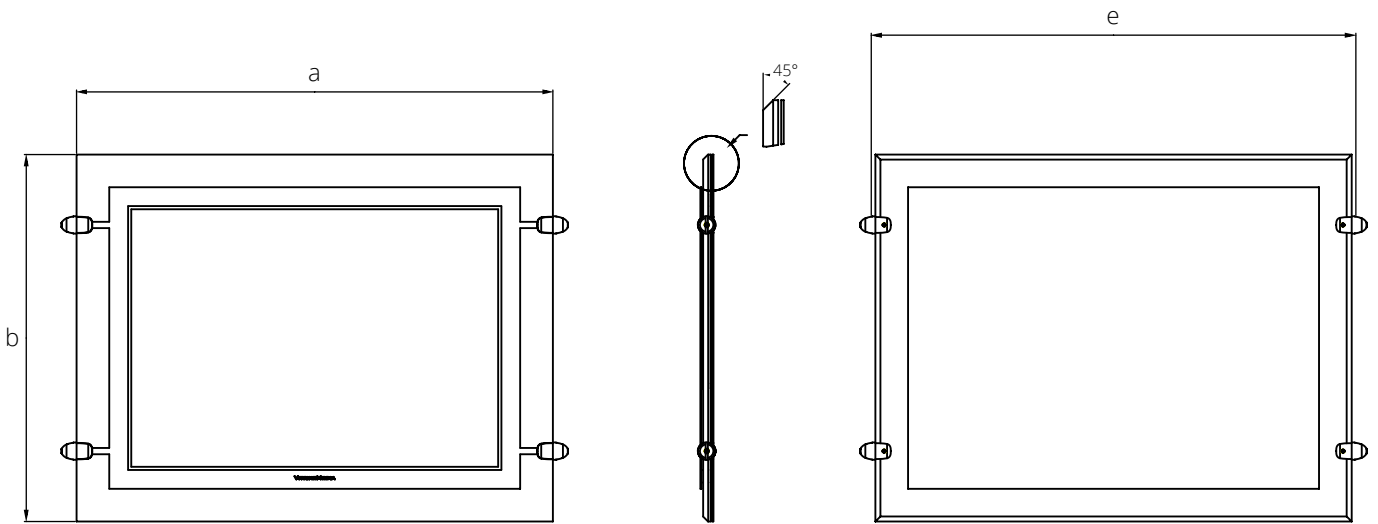

VM C2 MAX

Detailed Itemized List

- 1 x DOUBLE C2 MAX display panel
- 1 x S2 Allen Key
- 1 x S1.5 Allen Key
- 1 x Certificate of authenticity



Dimensions [mm]

	a	b	c	e	
A4	334	247	10	H a + 6	V b + 6
A3	457	334	10		
A2	631	457	10		
A1	878	631	10		

Technical Data

	Format	A4	A3	A2	A1
General	Supplier Reference	1012412017 (H) 1012412021 (V)	1012412018 (H) 1012412022 (V)	1012412019 (H) 1012412023 (V)	1012412020 (H) 1012412024 (V)
	VM Reference	C2M10D_A4H C2M10D_A4V	C2M10D_A3H C2M10D_A3V	C2M10D_A2H C2M10D_A2V	C2M10D_A1H C2M10D_A1V
	Orientation	Horizontal & Vertical			
	System	Suspended cables			
	Patent Number	FR2991489 ZO2013178747			
	Model Number	N/A			
	Weight (kg)	1.3	2.2	3.72	7.6
	Electricity	Incoming voltage (VCC)	24		
Power (W)		5	7.5	10.5	27
Max. Intensity (A)		0.245	0.35	0.49	1.8
Luminosity	One sided (LUX)	5400	5000	2900	2700
	Dual sided (LUX)	4700	4400	2500	2300

Logistical Data

Package size (mm)	328 x 25 x 415	415 x 25 x 538	538 x 25 x 712	712 x 26 x 959
Export box size (mm)	430 x 395 x 345	550 x 395 x 435	727 x 218 x 553	992 x 119 x 753
Units per export box	15	15	8	3
Gross weight per export box (Kg)	20.4	33.3	31.5	27

Product Use

Environment	Temperature	Humidity
Storage conditions	-5°C - 60°C	10% - 95% RH Uncondensed
Environment of use	0°C - 40°C	20% - 90% RH Uncondensed
Maintenance	No detergents or abrasive products	
Use	Up to 80 000 hrs	

