

# POWER BOX

Manuel (EU version)  
*Manual (EU version)*

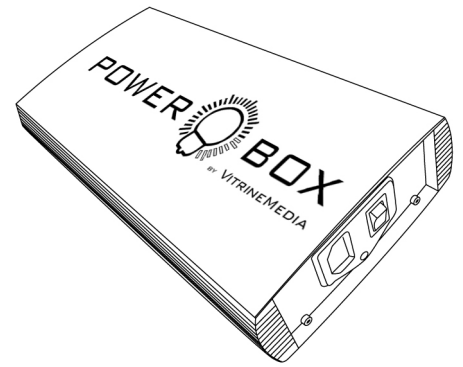

Contenu du kit de fixation / *Content of the fixation kit*

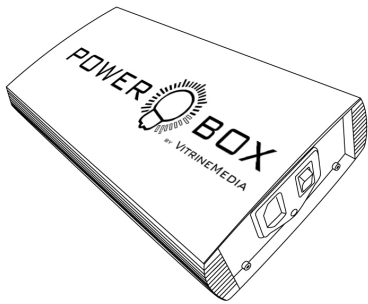

**Boitier Power Box (x1)**  
*Power Box (x1)*  
Ref. : 1022614001

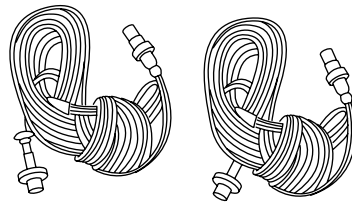

**Câble de connection Power Box - rail (x2)**  
*Power Box - Track connection cable (x2)*  
Ref. : 30301CN010

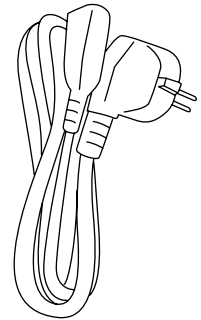

**Câble prise secteur Europe (x1)**  
*Power cord Europe (x1)*  
Ref. : 30301CN002

**1** Dévisser un bouchon.  
*Unscrew one cap.*

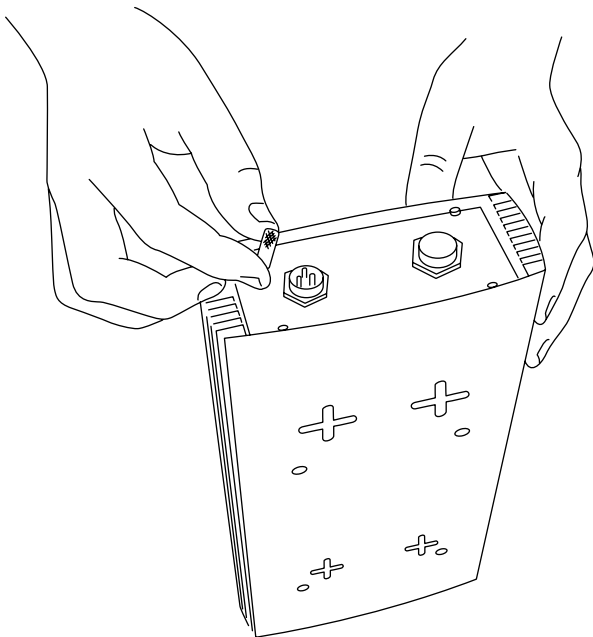

**2** Brancher et visser le câble d'alimentation du rail.  
*Plug and screw the power supply track cable.*

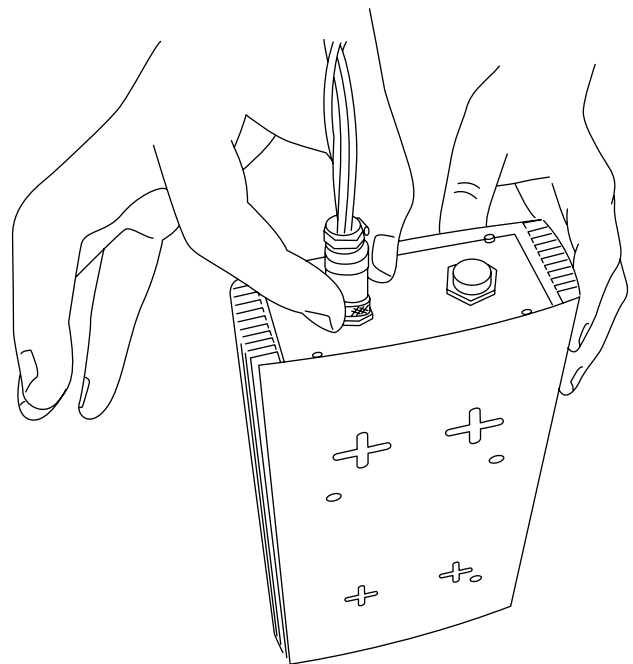

**3** Brancher le câble d'alimentation secteur.  
*Plug the power cord.*

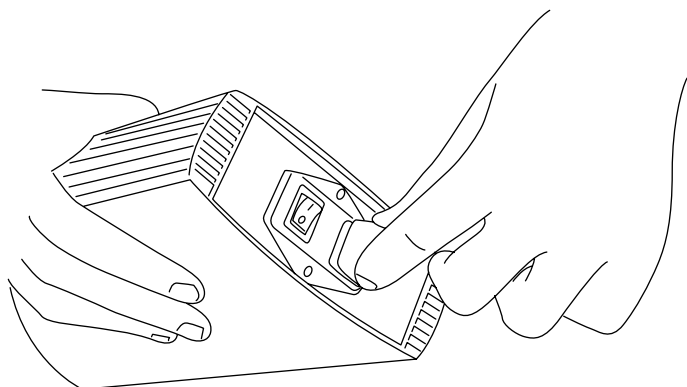

**4** Brancher la prise d'alimentation au secteur.  
*Plug the power cord to an AC outlet.*

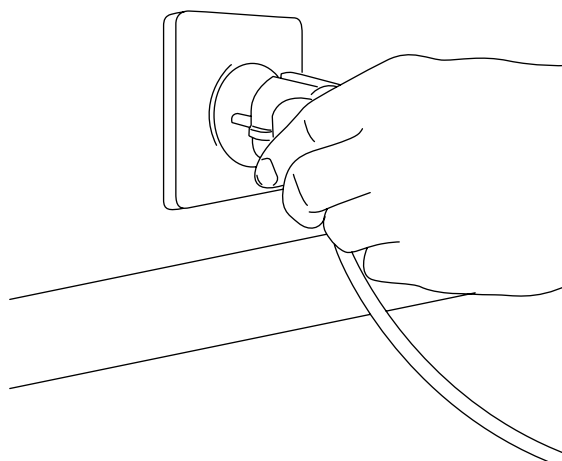

**5** Allumer la Power Box.  
*Switch on the Power Box.*

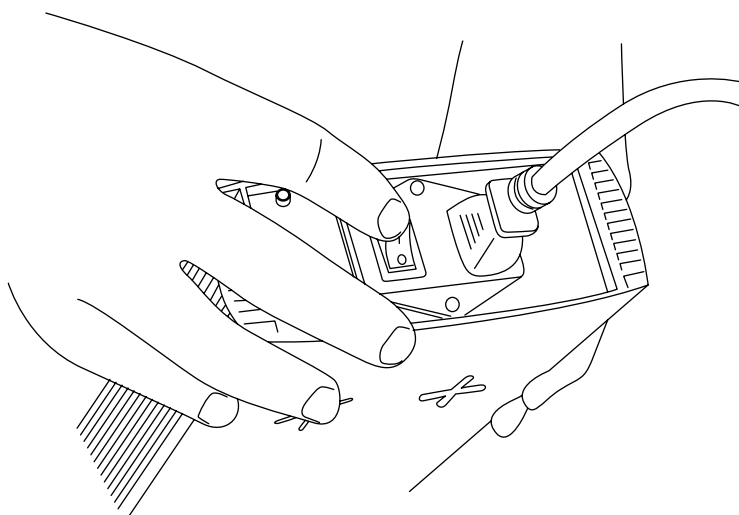

Normes Européennes et Internationales  
*European and International Standard*



Si vous souhaitez obtenir de l'aide, vous pouvez contacter le Service Après Vente. Avant de contacter VitrineMedia, notez le modèle et le numéro de série du produit. Vous trouverez ces informations directement sur le produit ou sur l'emballage.

*If you need help, you can contact our After Sale Service. Before contacting VitrineMedia, please write down the product model and serial number. You can find these informations directly on the product or on the packaging.*