

VI DOCUMENT HOLDER

Notice Utilisateur
User Guide

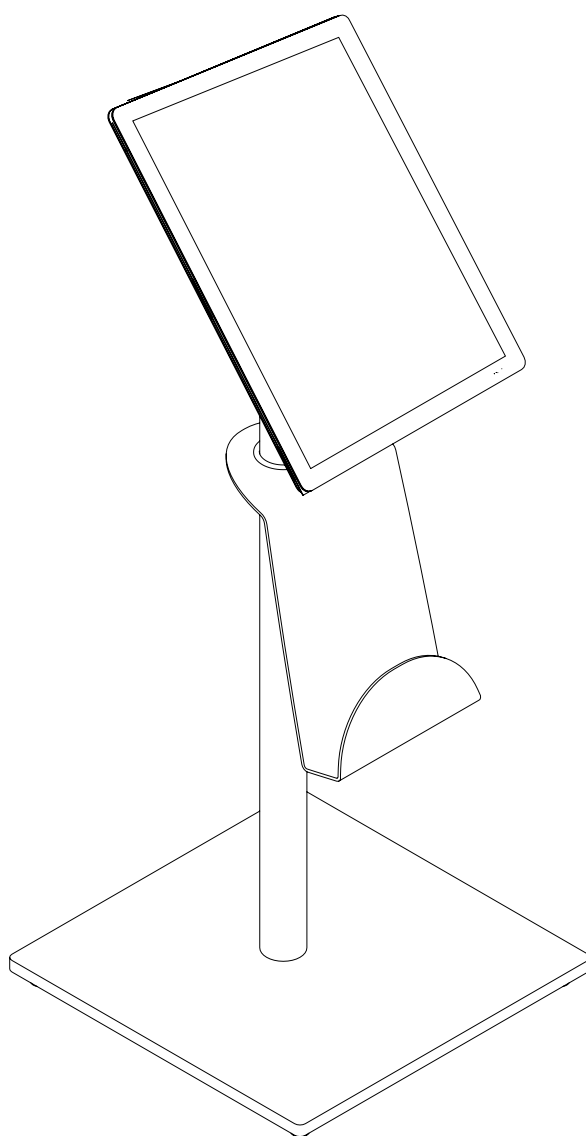

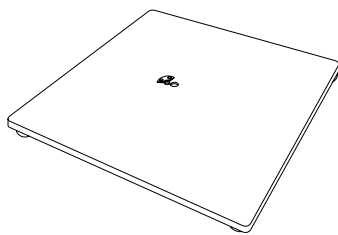

Platine de sol (x1)

Base plate (x1)
Ref 2010101014

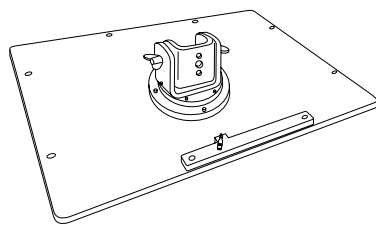

Ensemble écran pré-monté (x1)

Pre-assembled display screen (x1)
Ref 2010101056

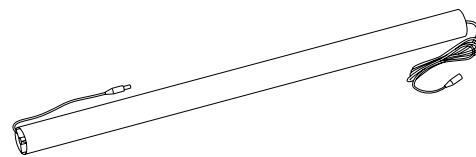

Jambe (x1)

Pole (x1)
Ref 2010101064

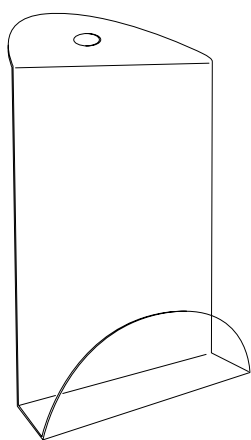

Porte-document (x1)

Document holder (x1)
Ref 2010101022

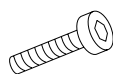

Vis (x2)

Screw (x2)
Ref 30701CN070

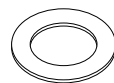

Rondelle (x2)

washer (x2)
Ref 30411C N049

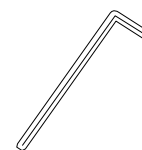

Clé Allen (x1)

Allen key (x1)
Ref 30702CN007

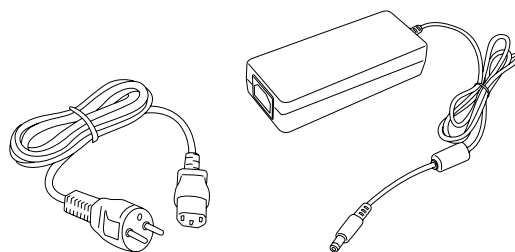

Alimentation électrique avec câble (x1)

Power supply and cord (x1)
Ref 30308CN001 / 30301CN002

NOTE : Effectuer le montage sur une surface protégée (tapis, draps de bain...)

WARNING : Assemble the unit on a protected surface (carpet, towel...)

- 1** Poser l'ensemble au sol, puis faire passer le câble femelle dans le grand trou de la platine .
Set the unit on the ground. Pass the female cable through the large hole on the base plate .

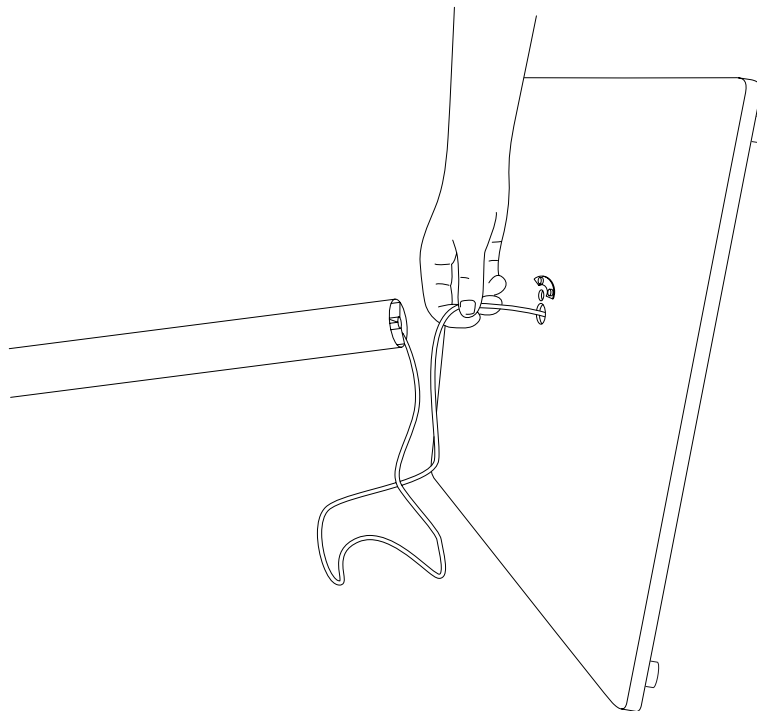

- 2** Enfiler la rondelle sur la vis. Insérer la vis munie de sa rondelle dans la jambe à travers le petit trou.
Slide the washer onto the screw. Insert the screw and through the small hole in the base plate and through the pole.

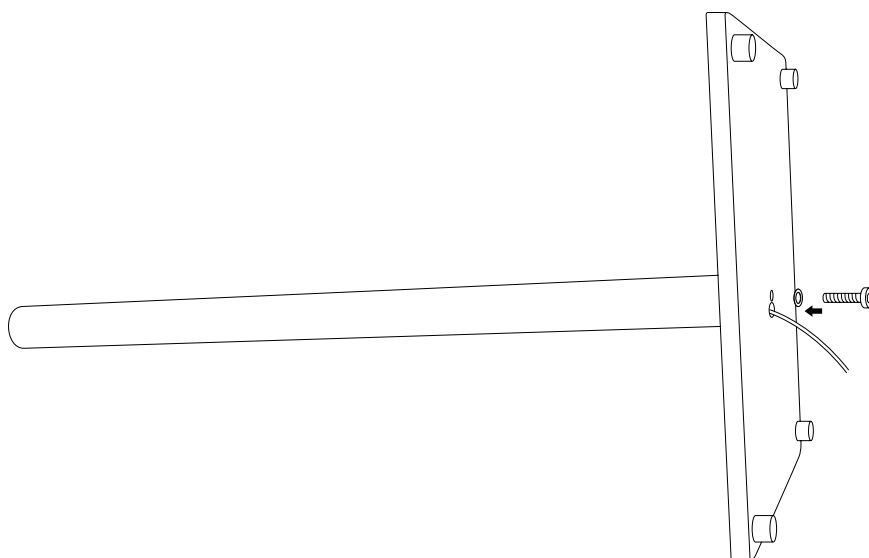

3 Serrer fortement la vis à l'aide de la clé Allen.
Tighten using the Allen key.

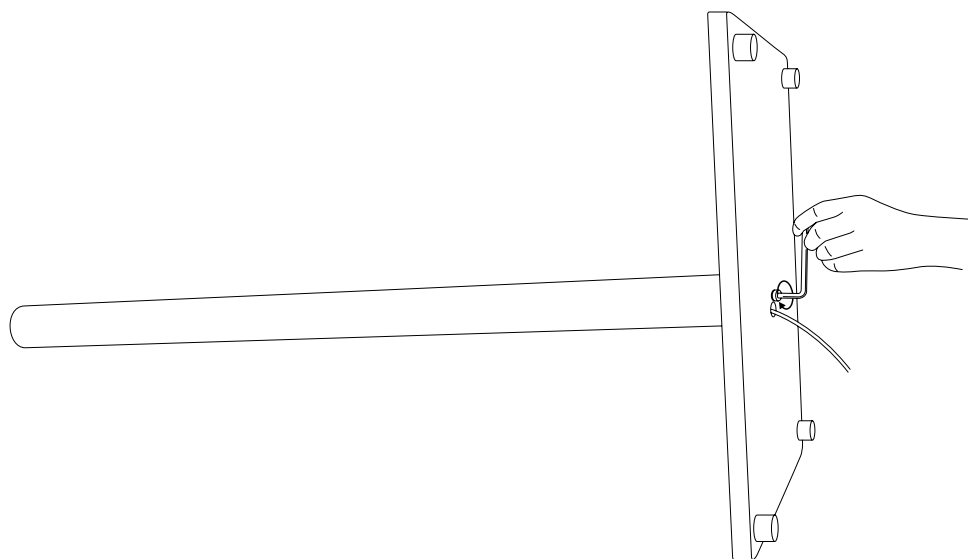

4 Ajuster la longueur du câble.
Adjust the cable length.

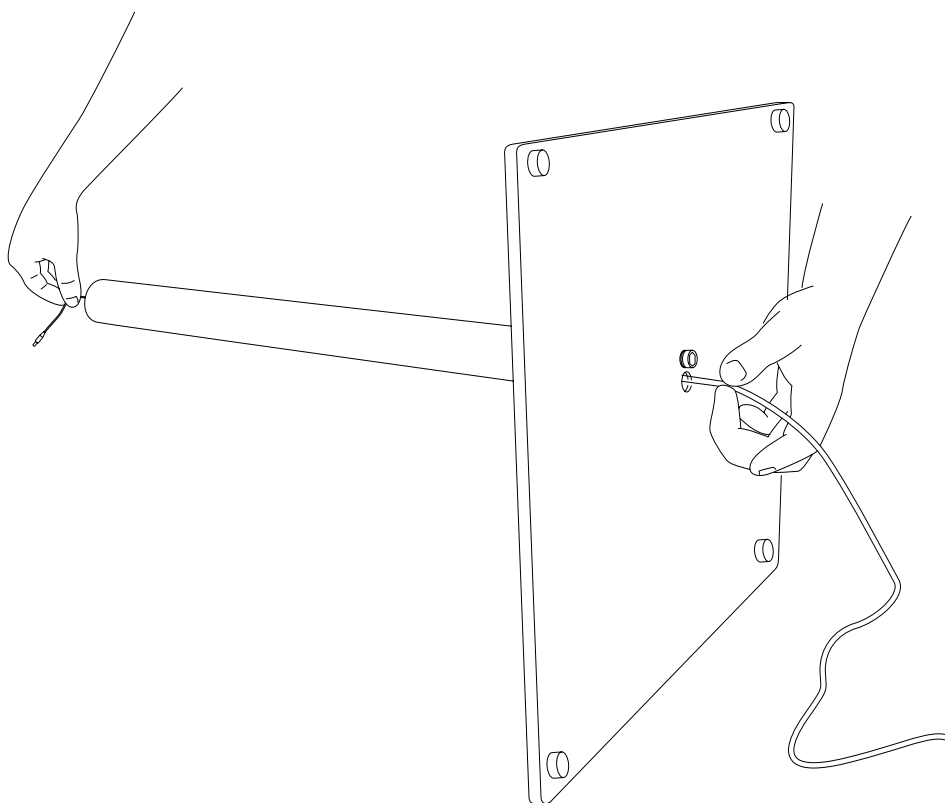

- 5** Redresser l'ensemble et faire glisser le porte-document sur la jambe.
Straighten the unit and slide the document holder onto the pole.

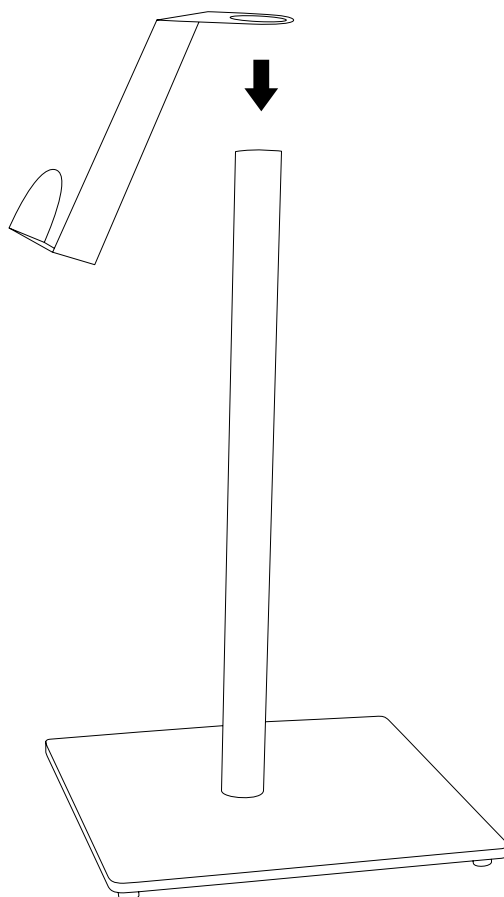

- 6** Enfiler la rondelle sur la vis, insérer la vis munie de sa rondelle à travers l'articulation (trou du milieu). Puis visser sur la jambe. L'articulation est inclinée vers le bas.
Slide the washer onto the screw, and insert it through the joint (through the hole in the middle). Screw it onto the pole. Tilt the joint downwards.

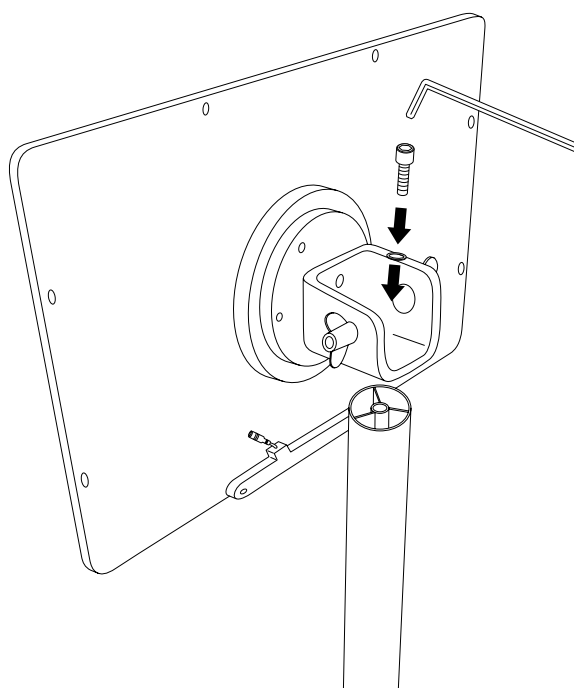

Pour incliner l'afficheur, il suffit de dévisser légèrement les papillons.

To tilt the display panel, simply lightly unscrew the butterfly nut to loosen it.

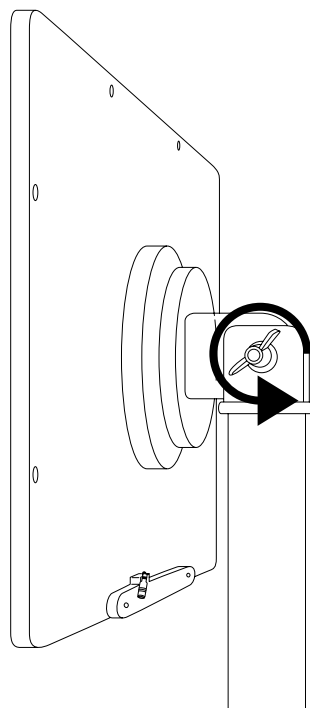

7 Brancher le câble à l'écran.

Connect the cable to the screen.

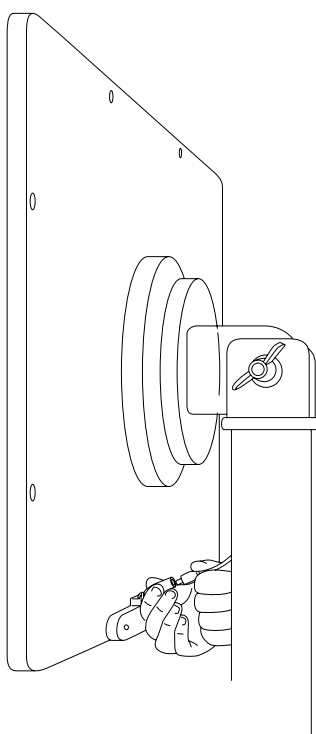

8 Brancher l'alimentation sur secteur.
Plug-in the power supply to the wall plug.

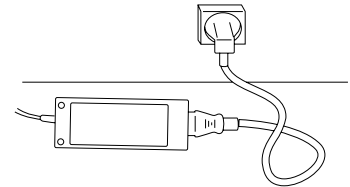
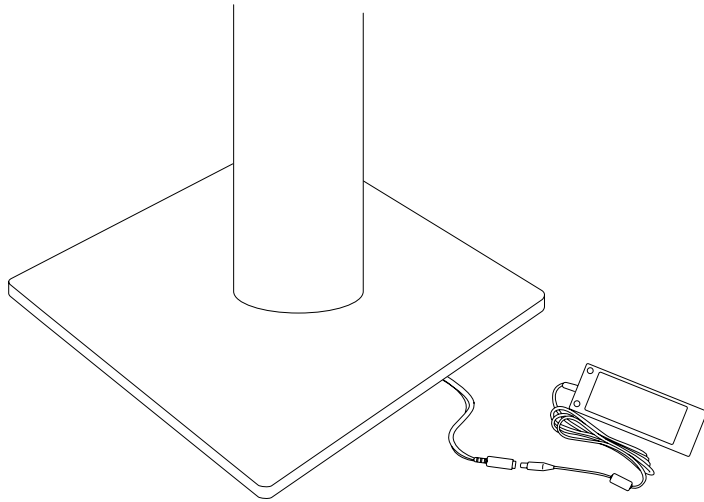

Normes Européennes et Internationales
European and International Standard



Si vous souhaitez obtenir de l'aide, vous pouvez contacter le Service Après Vente. Avant de contacter VitrineMedia, notez le modèle et le numéro de série du produit. Vous trouverez ces informations directement sur le produit ou sur l'emballage.

If you need help, you can contact our After Sale Service. Before contacting VitrineMedia, please write down the product model and serial number. You can find these informations directly on the product or on the packaging.

